

Specification (Test Condition, 25°C)

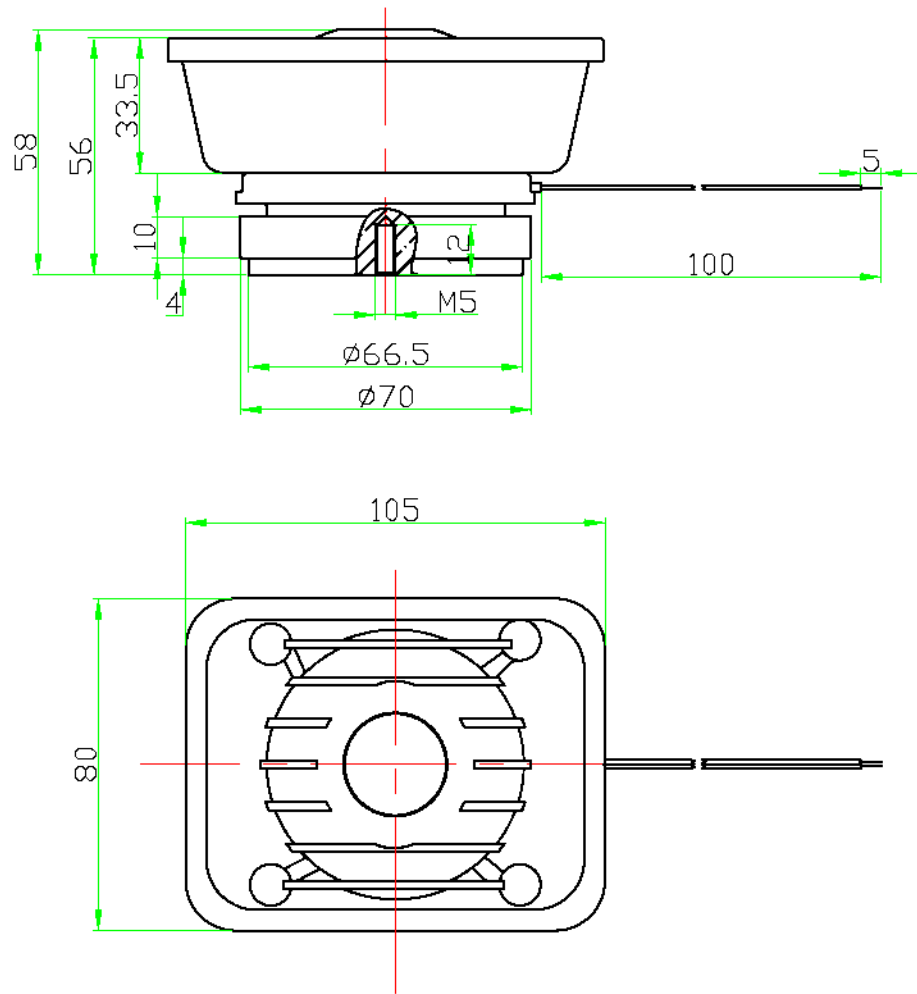

1. Housing Material/Color ABS/Blank
2. Voice Coil Impedance 8 Ohm (at 1 KHz)
3. Voice Coil Dimension Ø 25.4 mm(Dia.)
4. Magnet Size 70*32*10 mm(Dia.* dia.*H)
5. Power Rating RMS 20 W
6. Power Rating Peak 30 W
7. Frequency Range 500-8000Hz
8. Resonant Freq. Fo. 1.5 KHz ±10%
9. S.P.L. 95±3 dB(at 1 meter, 2.83V,1000Hz)
10. Load Test 8 Hours (at 8.94V,500-5000Hz)
11. Heat Test 8 Hours (at 60°C)
12. Operating Temperature Range -20 ~ +65°C
13. Wires Connection Black,white (Non-polarized)
14. Weight 350 ±20 g

				DSW NINGBO DSW AUDIO & SECURITY EQUIPMENT http://www.dswbrand.com	
No.	DESCRIPTION	APPROVED	DATE	Electronic Horn H-105	
<small>TOLERANCES UNLESS NOTED OTHERWISE</small> X = XX = XXX = 90° FORMED 12° ANGLES .12" FIRST ANGLE PROJECTION		APPROVALS			
		DRAWN			UNIT
		CHECKED		mm	E3.840.001.01G
		APPROVED		03.12.10	SCALE
				NOT TO SCALE	SHEET
					VER 1.0