

DSW™ *Protect Security*

INFRARED SENSOR

Sensor model DPS19(A、B&C)

Welcome to using DPS19(A、B&C) infrared motion sensor switch!

The product is a new energy-saving switch ,it adopts integrated circuit and the good sensitivity detector (DPS19B、C adopted SMT). It gathers automatism, convenience, safety, energy-saving and practicality function. The wide detection range is made up of the up and down, left and right service field. It works by receiving human motion infrared rays. It can start the controlled load at once when one enters the detection field. It can identify day and night automatically. Its using range is wide. It has the functions of the power indication and the detection indication.

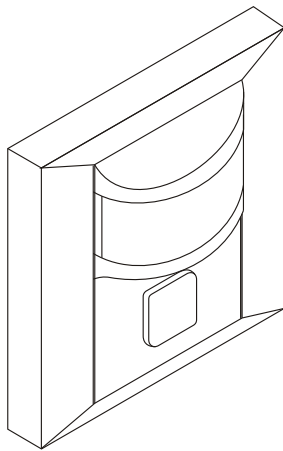

Specification:

Power source:100V/AC~130V/AC
220V/AC~240V/AC

Power frequency: 50~60Hz

Ambient light: <10LUX~2000LUX

Time-Delay: min:8sec±3sec

Max:7min±2min

Detection range: 120°

Detection distance: 9m max (<24°C)

Rated Load:

DPS19A&B: 400W(110V/AC~130V/AC)

600W(220V/AC~240V/AC)

DPS19C: 100W(110V/AC~130V/AC)

200W(220V/AC~240V/AC)

Working temperature: -20~40°C

Working humidity: <93%RH

Installation height:1m~1.6m

Power consumption:0.45W(static 0.1W)

Function:

• **Detection field:** The detection field is made up of up and down, left and right service field. (See the following diagram). But the moving orientation has great relationship with the sensitivity.

• **Can identify day and night:** The ambient light can be adjusted according to the consumer's desire , when it is adjusted on the “moon” “position (min), it can only work in

the less than 10LUX ambient light; It can work in the daytime and at night when it is adjusted on the “sun” position (max); As for the adjustment pattern, please refer to the testing pattern;

• **Time-delay is added continually:** When it receives the second induction signals after the first induction, it will compute time once more on the rest of the first time-delay basic.(set time)

• **Time-delay is adjustable:** It can be set according to the consumer's desire. The minimum time is 8sec±3sec. The maximum is 7min±2min.

• **The switch:** It is the “auto” condition when you push it in. It is “OFF” condition when you push it out.

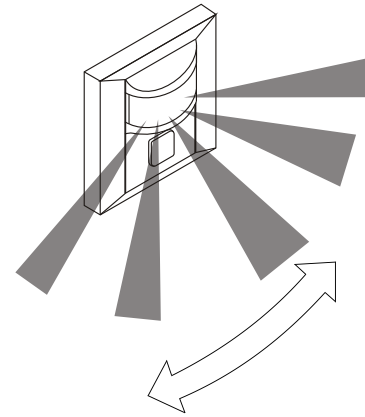

Correct moving orientation

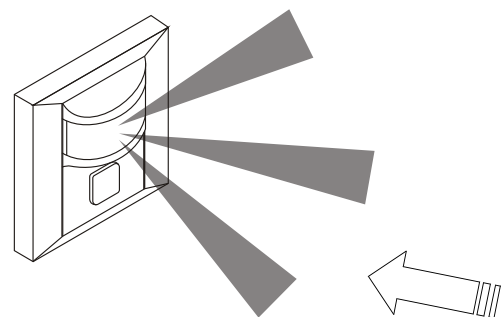
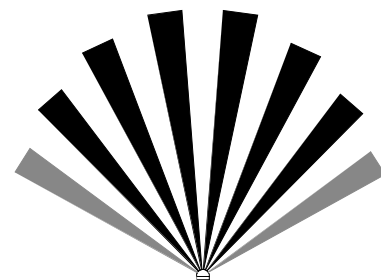

Incorrect moving orientation

Installation:(see the following diagram)

- Switch off the power.
- Lift the sensor board-face off and take off the nail.
- The power and the load wire with the sensor according to connection-wire diagram.
- The sensor is fixed on the selected position.
- You can switch on the power and test it after covering the board-face

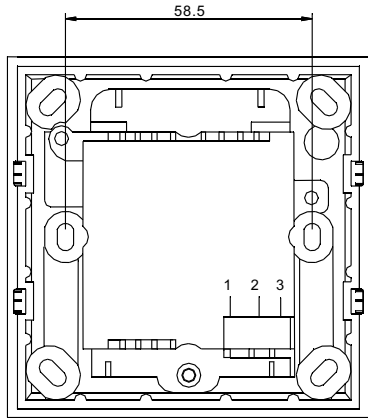
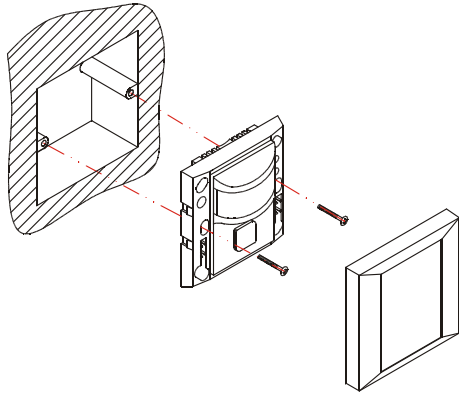

Connection-wire diagram:(see the right Fig)

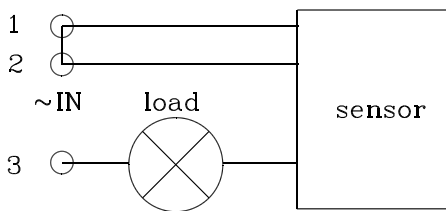
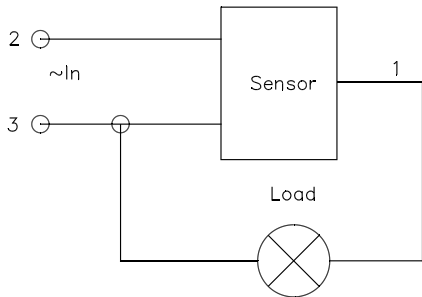

Test:

Turn the control-light knob anti-clockwise on the maximum ("sun" position), turn the time knob anti-clockwise on the minimum.

Switch on the power, the controlled load work after 5~10sec, under the no inductor signals conditions, the load should stop working within 5~30sec.

After the first is out, make it sense again after 5~10sec. The load should work and it stops working within 5~15sec.

Turn the light-control knob clockwise on the minimum, the inductor load should not work after the load stop working in the more than 10LUX ambient-light, the load

should work if you cover the detection window with the opaque object (towel etc). Under the no inductor signals conditions, it is normal for the load to stop working within 5~15sec.

Note:

- Electrician or experienced human can install it.
- The unrest objects can't be regarded the installation basis-face.
- There aren't hinder or unrest objects effecting detection in front of the detection window.
- Avoid installing it near temperature alteration zones, for example: air condition, central heating etc.
- Please don't open the case for your safety if you find the hitch after installation.

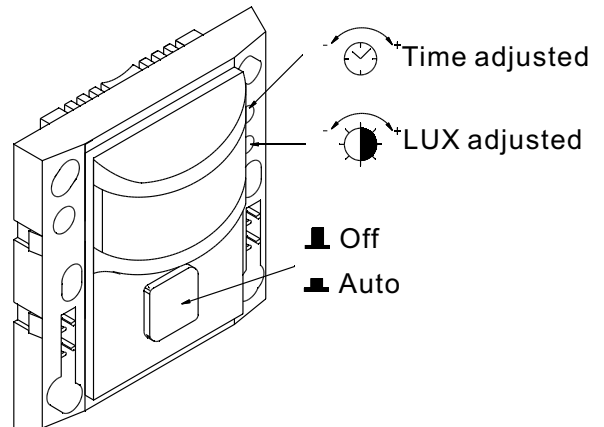

SOME PROBLEM AND SOLVED WAY :

1. The load don't work:

- Check the power and the load.
- If the function switch is in the "auto" condition.
- If the load is good.
- Please check if the working light correspond to the ambient- light.

2. The sensitivity is poor:

- Please check if the front of the detection window has the hinder that effect to receive the signals.
- Please check the ambient temperature.
- Please check if the signal source is in the detection field.
- Please check the installation height.
- If the moving orientation is correct.

3. The sensor can't shut off the load automatically:

- If there is continual sensor signal in the detection field.
- If the time-delay be set to the longest.
- If the power correspond to the instruction
- If the temperature change near the sensor. (air condition, central heating etc.)

Address: Room1121 Linqiao Piazza, Ningbo City,315010, China
 Tel:+86(574) 27861829 27861849
 Fax:+86(574)87264906
 E-mail: sales@dswbrand.com
 Http://www.DSW brand.COM